



2019 Tasar BC Championships

Jericho Sailing Centre

September 7th / 8th 2019

SAILING INSTRUCTIONS

1 Rules

- 1.1 The regatta will be governed by the current Racing Rules of Sailing (RRS), the prescriptions of the Canadian Yachting Association, the Class Rules of the World Tasar Class Association, except as any of these are changed by these sailing instructions or by the North American Tasar Association.
- 1.2 The North American Tasar Association has changed the Tasar Class rules as follows:
Rule C.6 Crew Weight does not apply.

2 Entries

- 2.1 Entry is open to all Tasars conforming to the Class Rules of the World Tasar Class Association as changed by 1.1.

3 Notices to Competitors

- 3.1 Notices to competitors will be posted on the official notice board(s) located in the JSCA lobby outside the JSCA office at 1300 Discovery Street.
- 3.2 Notices will also be posted on the JSCA racing website. Failure to post a notice to the website shall not be grounds for a protest by a boat.

4 Changes in Sailing Instructions

- 4.1 Any change to the sailing instructions will be posted on the day it will take effect at least 45 min prior to racing, except that any change to the schedule of races will be posted by 6 PM on the day before it will take effect.

5 Signals Made Ashore

- 5.1 Signals made ashore will be displayed on the flagpole adjacent to Ramp 2 at the east end of the JSCA building.
- 5.2 When flag AP is displayed ashore, '1 minute' is replaced with 'not less than 15 minutes' in race signal AP.

6 Schedule of Races

Please see Notice of Race

7 Racing Areas

- 7.1 The race area will be north of the JSCA unless conditions dictate otherwise.
- 7.2 The entire area bounded by the pier at the west end of JSCA, The RVYC breakwater, and the imaginary line created by the special purpose orange can buoys between these two references is out of bounds. All yachts shall pass to the north of this reference and any yacht sailing south of this reference shall be subject to disqualification

Sailing Instructions – 2019 Tasar BC Championships

8 The Course

- 8.1 The course to be sailed shall be displayed on the Race Committee boat before, or at the preparatory signal for each class. This modifies RRS 27.1

The course used will be indicated by code flags flown from the committee boat.

Course 1 (White pennant with red circle)	Standard Triangle
Course 2 (Blue pennant with white circle)	Windward – Leeward
Course 3 (Red, white, and blue pennant)	Bermudan Triangle
Course 4 (Red pennant with white cross)	2x Windward - Leeward

For course 2 or 4, mark 3A may be used as shown to make a leeward gate. Boats must finish the downwind leg by sailing through the gate, and may round either gate mark to begin the next leg.

Sailing through the start/finish line on the upwind/downwind legs of courses 2, 3 and 4 is permitted.

See page 5 for alternate courses with downwind finishes to be used if the committee boat is downwind of the leeward mark. Leeward gates will not be used with these alternate courses

- 8.2 The diagrams in Appendix A show the courses, including the approximate angles between legs, the order in which marks are to be passed, and the side on which each mark is to be left.

9 Marks

- 9.1 Marks 1, 2, 3, will be yellow or orange tetrahedrons.
- 9.2 The starting marks will be the orange paint on the mast and a red flag. The finishing marks will be the orange paint on the mast and a blue flag.

10 The Start

- 10.1 The starting line will be between the orange paint on the mast on the Committee boat on the starboard end and a staff displaying a red flag on the port end.
- 10.2 Yachts whose preparatory signal has not been made shall keep clear of the starting area and of all yachts whose preparatory signal has been made. If she interferes with those yachts in the race sequence she may be scored DSQ for her next/previous race.
- 10.3 Following a "General Recall Signal," RRS 30.1 (rounding the ends) may be displayed. The RC also has the option of displaying the Black Flag after a General Recall.
- 10.4 Races will be started according to RRS rule 26 as modified below.
- | | |
|-------|--------------------|
| 5 min | class flag up |
| 4 min | P flag (blue) up |
| 1 min | P flag (blue) down |
| Start | class flag down |
- 10.5 A boat starting later than 4 minutes after her starting signal will be scored Did Not Start. This changes rule A4.1.

Sailing Instructions – 2019 Tasar BC Championships

11 Changing The Position of the Next Mark

- 11.1 To change the position of the next mark, the race committee will lay a new mark (or move the finishing line) and remove the original mark as soon as practicable. The change will be signaled before the leading boat has begun the leg, although the new mark may not yet be in position. Any mark to be rounded after rounding the new mark may be relocated without further signaling to maintain the course configuration. When in a subsequent change a new mark is replaced, it will be replaced by an original mark.
- 11.2 Boats shall pass between the race committee boat signaling the change of course and the nearby mark, leaving the mark to port and the race committee boat to starboard. This changes rule 28.1.

12 The Finish

- 12.1 The finishing line will be between the orange paint on the mast on the committee boat on the port end and a staff displaying a blue flag on the starboard end.
- 12.2 The finish line shall rank as an obstruction unless finishing.

13 Penalties

- 13.1 A boat that has taken a penalty or retired under rule 31.2 or 44.1 shall inform the race committee as soon as practical and but no later than the end of the protest time limit.

14 Time Limit

- 14.1 No time limit is scheduled. The Race Committee may abandon a race at its discretion in accordance with RRS 32

15 Protests and Requests for Redress

- 15.1 Protest shall be written on protest forms (preferred) available from the JSCA office, located in the JSCA lobby. If protest forms are unavailable, protests may be written on a piece of paper which will be counted as an official protest.
- 15.2 Each completed protest form (or piece of paper) shall be handed in to the JSCA office.
- 15.3 The protest time limit is 30 minutes after the race committee reaches the beach after the last race of the day. The same protest time limit applies to all protests by the race committee and to requests for redress. This changes rules RRS 61.3 and RRS 62.2
- 15.4 A yacht wishing to pursue a protest shall report her protest to the Race Committee boat immediately after finishing a race.
- 15.5 Protest notices will be posted on the official notice board with 30 minutes of the protest time limit. The notices will indicate the location and time of the protest hearing, as well as a list of competitors who are either party to the protest, or who are named as witnesses.
- 15.6 Decisions of the jury will be final as provided in rule 70.4.

16 Scoring

- 16.1 The Low Point scoring system of Appendix A will apply.
- 16.2 Nine races are scheduled (although more may be sailed pending conditions), of which 1 race shall be completed to constitute a series.
- 16.3 (a) When fewer than 5 races have been completed, a boat's series score will be the total of her race scores (b) When 5 or more races have been completed, a boat's series score will be the total of her race scores excluding 20% of her worst scores

Sailing Instructions – 2019 Tasar BC Championships

17 Safety Regulations

17.1 A boat that retires from a race shall notify the race committee as soon as possible.

18. Replacement of Crew or Equipment

19.1 Substitution of competitors will not be allowed without prior approval of the race committee.

19.2 Substitution of damaged or lost equipment will not be allowed unless approved by the race committee. Requests for substitution shall be made to the race committee at the first reasonable opportunity.

19.3 Substitution of sails or sail numbers will not be allowed unless approved by the race committee. Requests for substitution shall be made to the race committee prior to the first race of the day.

The requirement for approval of the Race committee will be waived if the competitor provides the RC with written notice of the intended sail change. Signing in on the sign in sheet shall meet the requirements of written notice

20 Equipment and Measurement Checks

20.1 A boat or equipment may be inspected at any time for compliance with the class rules and sailing instructions. On the water, a boat can be instructed by a race committee measurer to proceed immediately to a designated area for inspection.

21 Official Boats

21.1 Official boats will be the Albatross, Jericho Rescue, and Jericho Marks.

22 Support Boats

22.1 Team leaders, coaches and other support personnel shall stay outside areas where boats are racing from the time of the preparatory signal for the first class to start until all boats have finished or the race committee signals a postponement, general recall or abandonment.

23 Disclaimer of Liability

23.1 Competitors participate in the regatta entirely at their own risk. (See rule 4, Decision to Race). The organizing authority will not accept any liability for material damage or personal injury or death sustained in conjunction with or prior to, during, or after the regatta.

24 Prizes

Prize giving will be at the Jericho Sailing Centre as soon as possible after the completion of racing on Sunday.

Sailing Instructions – 2019 Tasar BC Championships

Appendix A Courses.

Course 1. S - 1 - 2 - 3 - F

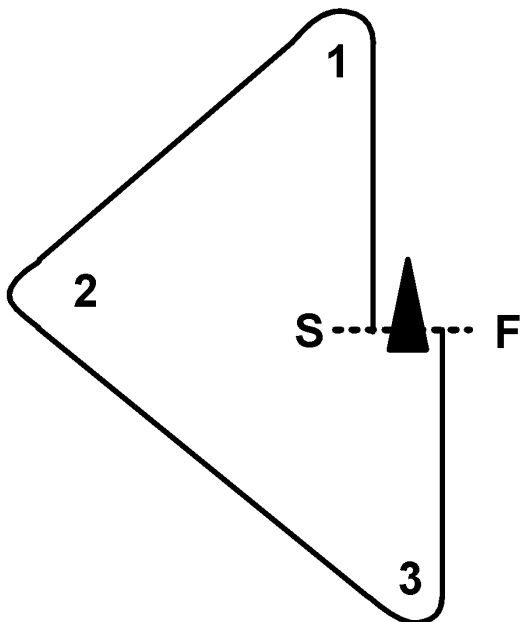

Course 2. S - 1 - 3 - F

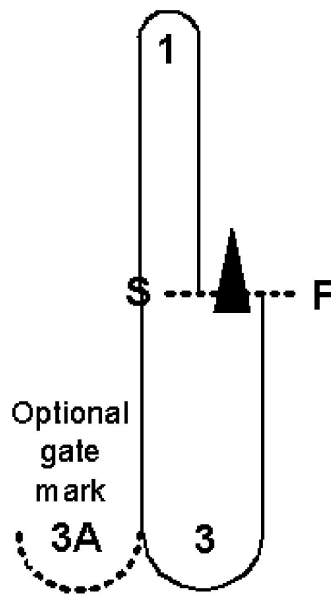

Course 3. S - 1 - 2 - 3 - 1 - 3 - F

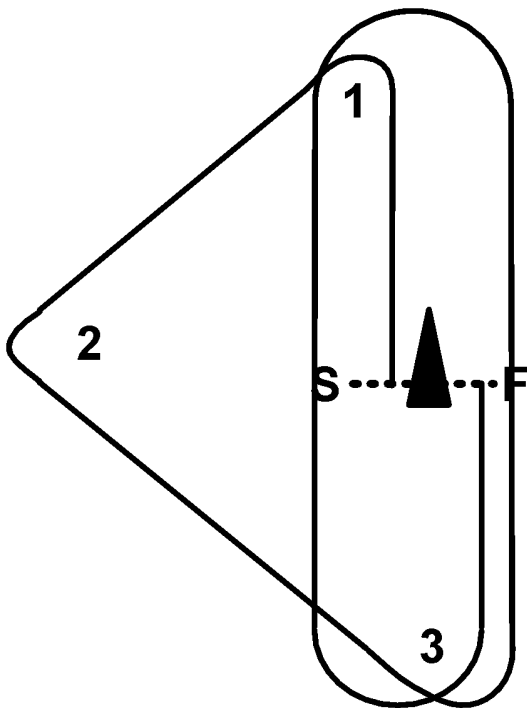

Course 4. S - 1 - 3 - 1 - 3 - F

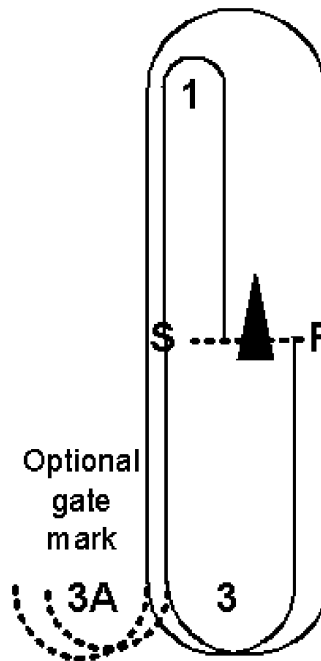

Alternate Courses, to be used if the committee boat is downwind of the leeward mark

Sailing Instructions – 2019 Tasar BC Championships

Course 1. S - 1 - 2 - 3 - F

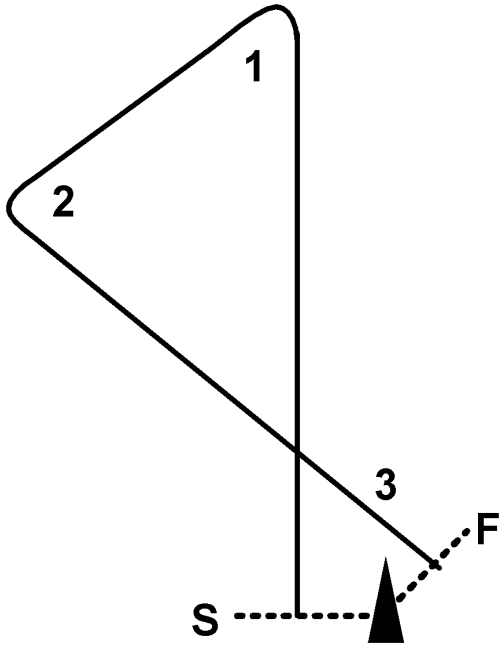

Course 2. S - 1 - 3 - F

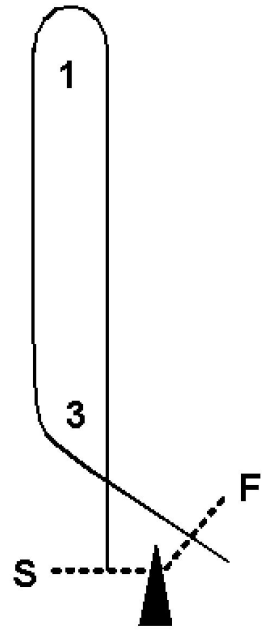

Course 3. S - 1 - 2 - 3 - 1 - 3 - F

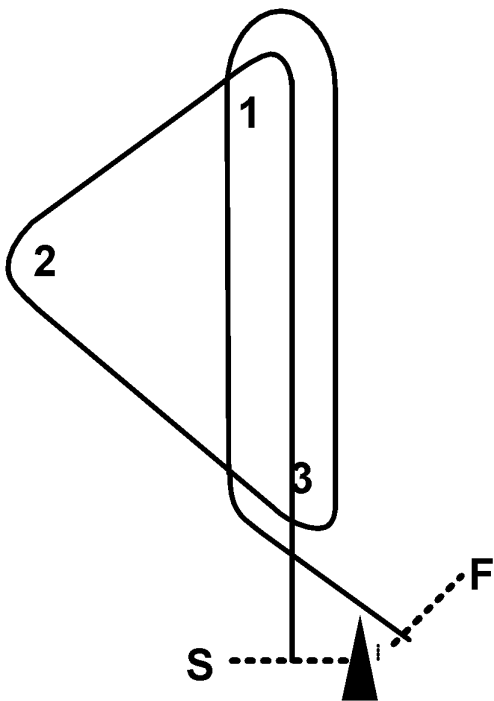

Course 4. S - 1 - 3 - 1 - 3 - F

